

isc Silicon NPN Power Transistor

2SC3280

DESCRIPTION

- Collector-Emitter Breakdown Voltage-
: $V_{(BR)CEO} = 160V(\text{Min})$
- Collector-Emitter Saturation Voltage-
: $V_{CE(sat)} = 2.0V(\text{Max}) @ I_C = 8A$
- Complement to Type 2SA1301

APPLICATIONS

- Power amplifier applications
- Recommend for 80W high fidelity audio frequency amplifier output stage applications

ABSOLUTE MAXIMUM RATINGS($T_a=25^\circ\text{C}$)

SYMBOL	PARAMETER	VALUE	UNIT
V_{CBO}	Collector-Base Voltage	160	V
V_{CEO}	Collector-Emitter Voltage	160	V
V_{EBO}	Emitter-Base voltage	5	V
I_C	Collector Current-Continuous	12	A
I_B	Base Current-Continuous	1.2	A
P_C	Collector Power Dissipation @ $T_C=25^\circ\text{C}$	120	W
T_J	Junction Temperature	150	$^\circ\text{C}$
T_{stg}	Storage Temperature Range	-55~150	$^\circ\text{C}$

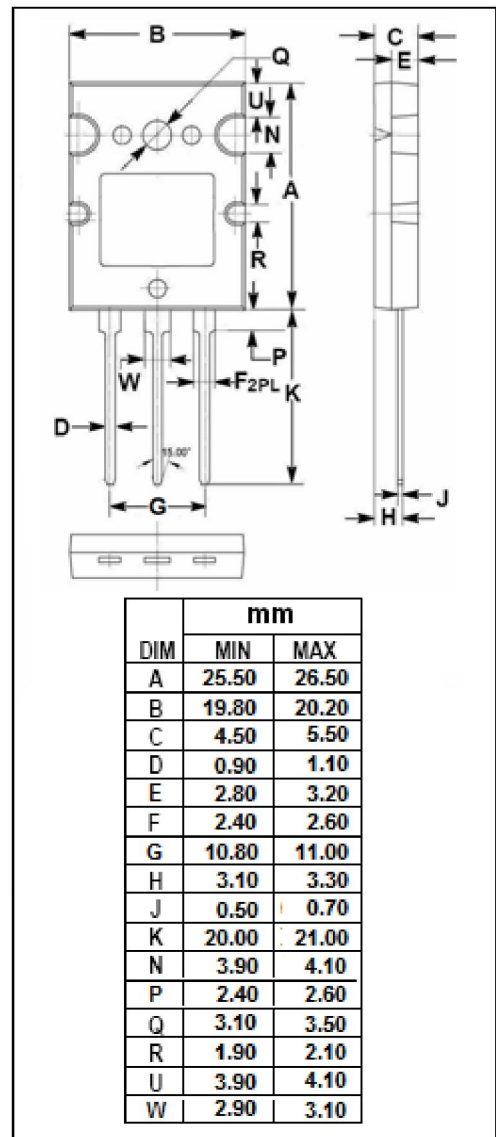
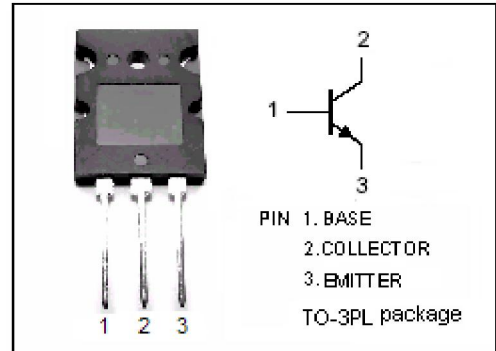

isc Silicon NPN Power Transistor**2SC3280****ELECTRICAL CHARACTERISTICS** $T_C=25^{\circ}\text{C}$ unless otherwise specified

SYMBOL	PARAMETER	CONDITIONS	MIN	TYP.	MAX	UNIT
$V_{(BR)CEO}$	Collector-Emitter Breakdown Voltage	$I_C=50\text{mA}; I_B=0$	160			V
$V_{CE(sat)}$	Collector-Emitter Saturation Voltage	$I_C=8\text{A}; I_B=0.8\text{A}$			2.0	V
$V_{BE(on)}$	Base-Emitter On Voltage	$I_C=6\text{A}; V_{CE}=5\text{V}$			1.5	V
I_{CBO}	Collector Cutoff Current	$V_{CB}=160\text{V}; I_E=0$			5.0	μA
I_{EBO}	Emitter Cutoff Current	$V_{EB}=5\text{V}; I_C=0$			5.0	μA
h_{FE-1}	DC Current Gain	$I_C=1\text{A}; V_{CE}=5\text{V}$	55		160	
h_{FE-2}	DC Current Gain	$I_C=6\text{A}; V_{CE}=5\text{V}$	35			
f_T	Current-Gain—Bandwidth Product	$I_C=1\text{A}; V_{CE}=5\text{V}$		30		MHz
C_{OB}	Output Capacitance	$I_E=0; V_{CB}=10\text{V}; f_{test}=1\text{MHz}$		220		pF

◆ **h_{FE-1} Classifications**

R	O
55-110	80-160