

isc Silicon NPN Power Transistor

2SC3457

DESCRIPTION

- High Breakdown Voltage-
: $V_{(BR)CBO} = 1100V(\text{Min})$
- Fast Switching Speed
- Wide Area of Safe Operation

APPLICATIONS

- Designed for switching regulator Applications

ABSOLUTE MAXIMUM RATINGS($T_a=25^\circ\text{C}$)

SYMBOL	PARAMETER	VALUE	UNIT
V_{CBO}	Collector-Base Voltage	1100	V
V_{CEO}	Collector-Emitter Voltage	800	V
V_{EBO}	Emitter-Base Voltage	7	V
I_C	Collector Current-Continuous	3	A
I_{CM}	Collector Current-Peak	10	A
I_B	Base Current-Continuous	1.5	A
P_C	Collector Power Dissipation @ $T_C=25^\circ\text{C}$	50	W
T_J	Junction Temperature	150	$^\circ\text{C}$
T_{stg}	Storage Temperature Range	-55~150	$^\circ\text{C}$

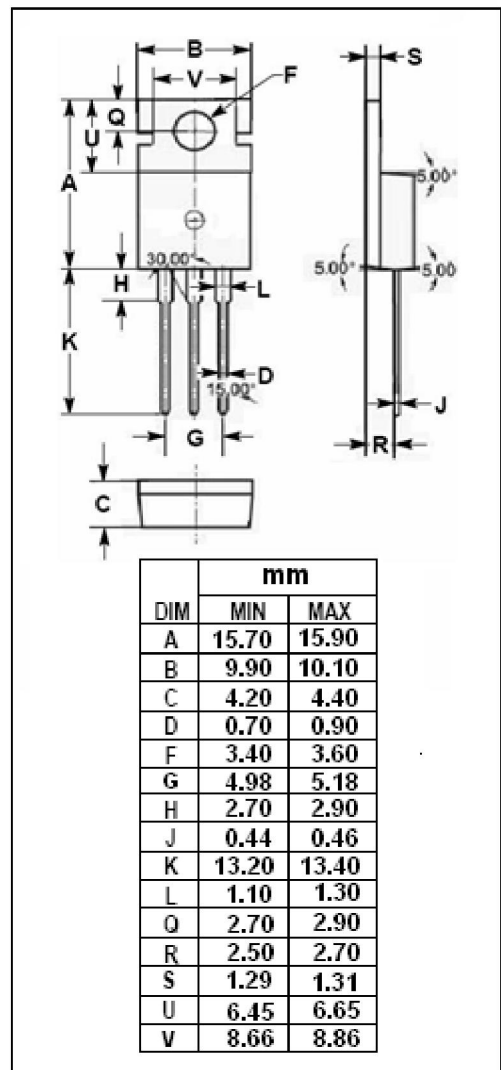
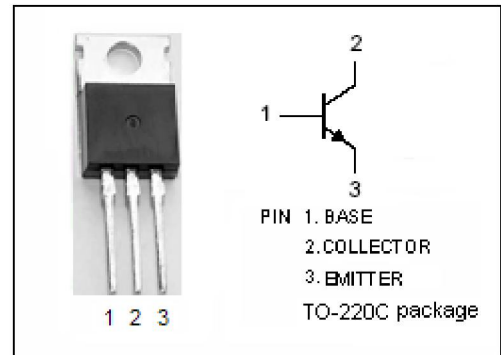

isc Silicon NPN Power Transistor

2SC3457

ELECTRICAL CHARACTERISTICS

 $T_C=25^{\circ}\text{C}$ unless otherwise specified

SYMBOL	PARAMETER	CONDITIONS	MIN	TYP.	MAX	UNIT
$V_{(BR)CEO}$	Collector-Emitter Breakdown Voltage	$I_C=5\text{mA}; R_{BE}=\infty$	800			V
$V_{CEO(SUS)}$	Collector-Emitter Sustaining Voltage	$I_C=1.5\text{A}; I_{B1}=-I_{B2}=0.3\text{A}; L=2\text{mH}; \text{clamped}$	800			V
$V_{(BR)CBO}$	Collector-Base Breakdown Voltage	$I_C=1\text{mA}; I_E=0$	1100			V
$V_{(BR)EBO}$	Emitter-Base Breakdown Voltage	$I_E=1\text{mA}; I_C=0$	7			V
$V_{CE(sat)}$	Collector-Emitter Saturation Voltage	$I_C=1.5\text{A}; I_B=0.3\text{A}$			2.0	V
$V_{BE(sat)}$	Base-Emitter Saturation Voltage	$I_C=1.5\text{A}; I_B=0.3\text{A}$			1.5	V
I_{CBO}	Collector Cutoff Current	$V_{CB}=800\text{V}; I_E=0$			10	μA
I_{EBO}	Emitter Cutoff Current	$V_{EB}=5\text{V}; I_C=0$			10	μA
h_{FE-1}	DC Current Gain	$I_C=0.2\text{A}; V_{CE}=5\text{V}$	10		40	
h_{FE-2}	DC Current Gain	$I_C=1\text{A}; V_{CE}=5\text{V}$	8			
C_{OB}	Output Capacitance	$I_E=0; V_{CB}=10\text{V}; f_{\text{test}}=1.0\text{MHz}$		60		pF
f_T	Current-Gain—Bandwidth Product	$I_C=0.2\text{A}; V_{CE}=10\text{V}$		15		MHz

Switching times

t_{on}	Turn-on Time	$I_C=2\text{A}, I_{B1}=0.4\text{A}; I_{B2}=-0.8\text{A}$ $R_L=200\Omega; V_{CC}=400\text{V}$			0.5	μs
t_{stg}	Storage Time				3.0	μs
t_f	Fall Time				0.3	μs

◆ h_{FE-1} Classifications

K	L	M
10-20	15-30	20-40