

1 A step-down switching regulator

Datasheet - production data

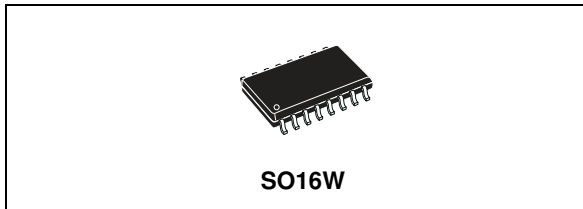

Description

The L4976 is a step-down monolithic power switching regulator delivering 1 A at a voltage between 3.3 V and 50 V (selected by a simple external divider). Realized in BCD mixed technology, the device uses an internal power D-MOS transistor (with a typical $R_{ds(ON)}$ of 0.25 Ω) to obtain very high efficiency and high switching speed. A switching frequency up to 300 kHz is achievable (the maximum power dissipation of the packages must be observed). A wide input voltage range between 8 V to 55 V and output voltages regulated from 3.3 V to 40 V cover the majority of today's applications. Features of this new generations of DC-DC converter include pulse-by-pulse current limit, hiccup mode for short circuit protection, voltage feedforward regulation, protection against feedback loop disconnection and thermal shutdown. The device is available in plastic dual in line, SO16W for SMD assembly.

Features

- Up to 1 A step-down converter
- Operating input voltage from 8 V to 55 V
- Precise 5.1 V reference voltage
- Output voltage adjustable from 0.5 V to 50 V
- Switching frequency adjustable up to 300 kHz
- Voltage feed-forward
- Zero load current operation
- Internal current limiting (pulse-by-pulse and hiccup mode)
- Protection against feedback disconnection
- Thermal shutdown

Figure 1. Application circuit

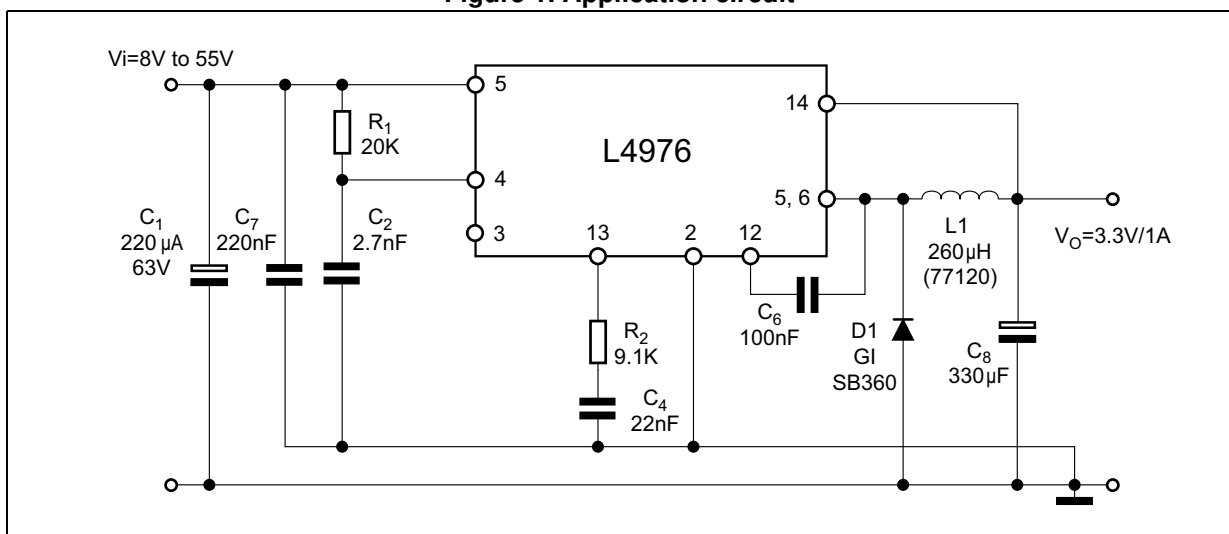

Contents

- 1 Block diagram 3**

- 2 Pin settings 4**
 - 2.1 Pin connection 4
 - 2.2 Pin description 4

- 3 Electrical data 5**
 - 3.1 Maximum ratings 5
 - 3.2 Thermal data 5
 - 3.3 Operating temperature rating 5

- 4 Electrical characteristics 6**

- 5 Typical characteristics 8**

- 6 Package mechanical data 13**

- 7 Order code 15**

- 8 Revision history 16**

1 Block diagram

Figure 2. Block diagram

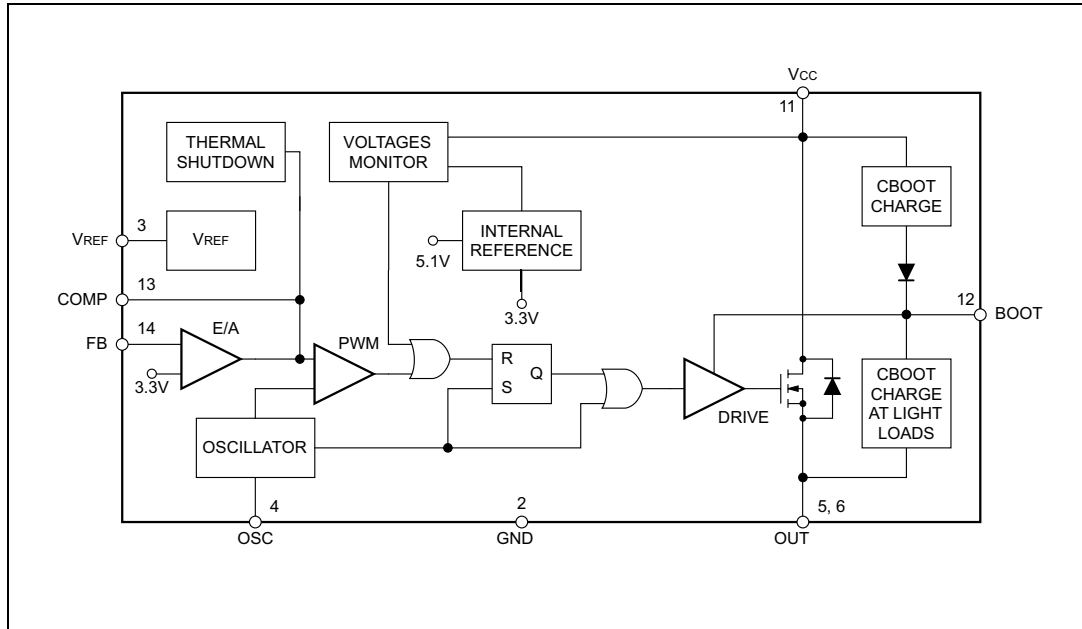

2 Pin settings

2.1 Pin connection

Figure 3. Pin connection (top view)

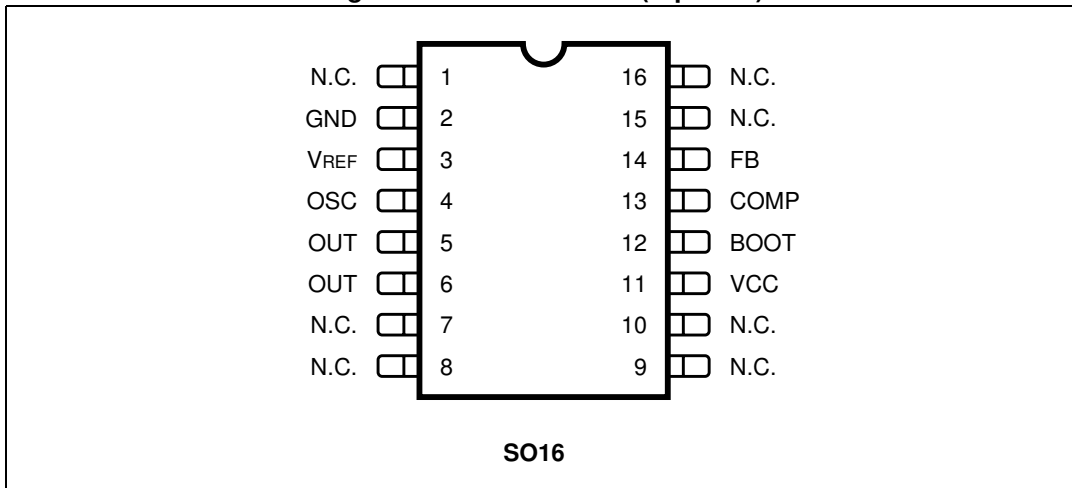

2.2 Pin description

Table 1. Pin description

N° Pin ⁽¹⁾	Name	Description
2	GND	Ground
3	VREF	5.1 V Reference voltage with 20 mA current capability.
4	OSC	An external resistor connected between the unregulated input voltage and this pin and a capacitor connected from this pin to ground fix the switching frequency. (Line feed forward is automatically obtained)
5, 6	OUT	Stepdown regulator output.
11	VCC	Unregulated DC input voltage.
12	BOOT	A capacitor connected between this pin and OUT allows to drive the internal VDMOS.
13	COMP	E/A output to be used for frequency compensation.
14	FB	Stepdown feedback input. Connecting directly to this pin results in an output voltage of 3.3 V. An external resistive divider is required for higher output voltages.

1. Pins 1, 7, 8, 9, 10, 15 and 16 are not internally, electrically connected to the die.

3 Electrical data

3.1 Maximum ratings

Table 2. Absolute maximum ratings

Symbol	Parameter		Value	Unit
V11	Input voltage		58	V
V5, V6	Output DC voltage		-1	V
	Output peak voltage at $t = 0.1 \mu\text{s}$, $f = 200 \text{ kHz}$		-5	V
I5, I6	Maximum output current		internal limit	
V12-V11			14	V
V12	Bootstrap voltage		70	V
V13	Analog input voltage ($V_{CC} = 24 \text{ V}$)		12	V
V14	($V_{CC} = 20 \text{ V}$)		6	V
			-0.3	V
P _{TOT}	Power dissipation at $T_A \leq 60^\circ\text{C}$	SO16	0.8	W
T _J , T _{STG}	Junction and storage temperature		-40 to 150	°C

3.2 Thermal data

Table 3. Thermal data

Symbol	Parameter	SO16W	Unit
R _{thJA}	Maximum thermal resistance junction-ambient	110 ⁽¹⁾	°C/W

1. Package mounted on board

3.3 Operating temperature rating

Table 4. Operating temperature rating

Symbol	Parameter	Value	Unit
T _J	Junction temperature range	-40 to 150	°C

4 Electrical characteristics

Table 5. Electrical characteristics
($T_J = 25^\circ\text{C}$, $C_{\text{OSC}} = 2.7\text{nF}$, $R_{\text{OSC}} = 20\text{k}\Omega$, $V_{\text{CC}} = 24\text{V}$, unless otherwise specified.)

Symbol	Parameter	Test condition	Min	Typ	Max	Unit
Dynamic characteristic						
V_I	Operating input voltage range	$V_O = 3.3$ to 50V ; $I_O = 1\text{A}$ ⁽¹⁾	8		55	V
V_O	Output voltage	$I_O = 0.5\text{A}$	3.33	3.36	3.39	V
		$I_O = 0.2$ to 1A	3.292	3.36	3.427	V
		$V_{\text{CC}} = 8$ to 55V ⁽¹⁾	3.22	3.36	3.5	V
V_d	Dropout voltage	$V_{\text{CC}} = 10\text{V}$; $I_O = 1\text{A}$		0.29	0.367	V
		⁽¹⁾			0.587	V
I_L	Maximum limiting current	$V_{\text{CC}} = 8$ to 55V ⁽¹⁾	1.5	2	2.5	A
	Efficiency	$V_O = 3.3\text{V}$; $I_O = 1\text{A}$		85		%
f_s	Switching frequency	⁽¹⁾	90	100	110	kHz
SVRR	Supply voltage ripple rejection	$V_I = V_{\text{CC}} + 2V_{\text{RMS}}$; $V_O = V_{\text{ref}}$; $I_O = 1\text{A}$; $f_{\text{ripple}} = 100\text{Hz}$	60			dB
	Voltage stability of switching frequency	$V_{\text{CC}} = 8$ to 55V		3	6	%
	Temp. stability of switching frequency	$T_J = 0$ to 125°C		4		%
Reference section						
	Reference voltage		5.0	5.1	5.2	V
		$I_{\text{ref}} = 0$ to 10mA ; ⁽¹⁾ $V_{\text{CC}} = 8$ to 55V	4.950	5.1	5.250	V
	Line regulation	$I_{\text{ref}} = 0\text{mA}$; $V_{\text{CC}} = 8$ to 55V		5	10	mV
		Load regulation	$V_{\text{ref}} = 0$ to 5mA ; $V_{\text{CC}} = 0$ to 20mA		2	
	Short circuit current		30	65	100	mA

Table 5. Electrical characteristics (continued)
 ($T_J = 25^\circ\text{C}$, $C_{OSC} = 2.7\text{nF}$, $R_{OSC} = 20\text{k}\Omega$, $V_{CC} = 24\text{V}$, unless otherwise specified.)

Symbol	Parameter	Test condition	Min	Typ	Max	Unit
DC Characteristics						
I_{QOP}	Total operating quiescent current			4	6	mA
I_Q	Quiescent current	Duty Cycle = 0; $V_{FB} = 3.8\text{V}$		2.5	3.5	mA
Error Amplifier						
V_{FB}	Voltage feedback input		3.33	3.36	3.39	V
R_L	Line regulation	$V_{CC} = 8$ to 55V		5	10	mV
	Ref. voltage stability vs temperature	(1)		0.4		$\text{mV}/^\circ\text{C}$
V_{OH}	High level output voltage	$V_{FB} = 2.5\text{V}$	10.3			V
V_{OL}	Low level output voltage	$V_{FB} = 3.8\text{V}$			0.65	V
$I_{O\text{ source}}$	Source output current	$V_{comp} = 6\text{V}$; $V_{FB} = 2.5\text{V}$	180	220		μA
$I_{O\text{ sink}}$	Sink output current	$V_{comp} = 6\text{V}$; $V_{FB} = 3.8\text{V}$	200	300		μA
I_b	Source bias current			2	3	μA
SVRR E/A	Supply voltage ripple rejection	$V_{comp} = V_{fb}$; $V_{CC} = 8$ to 55V	60	80		dB
	DC open loop gain	$R_L = \infty$	50	57		dB
gm	Transconductance	$I_{comp} = -0.1$ to 0.1mA $V_{comp} = 6\text{V}$		2.5		ms
Oscillator section						
	Ramp valley		0.78	0.85	0.92	V
	Ramp peak	$V_{CC} = 8\text{V}$	2	2.15	2.3	V
		$V_{CC} = 55\text{V}$	9	9.6	10.2	V
	Maximum duty cycle		95	97		%
	Maximum frequency	Duty cycle = 0% $R_{osc} = 13\text{k}\Omega$, $C_{osc} = 820\text{pF}$			300	kHz

1. Specification referred to T_J from 0 to 125°C

5 Typical characteristics

Figure 4. Quiescent drain current vs. input voltage

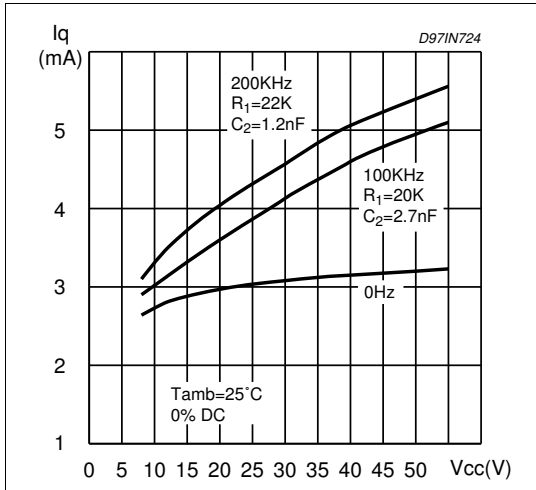

Figure 5. Line regulation

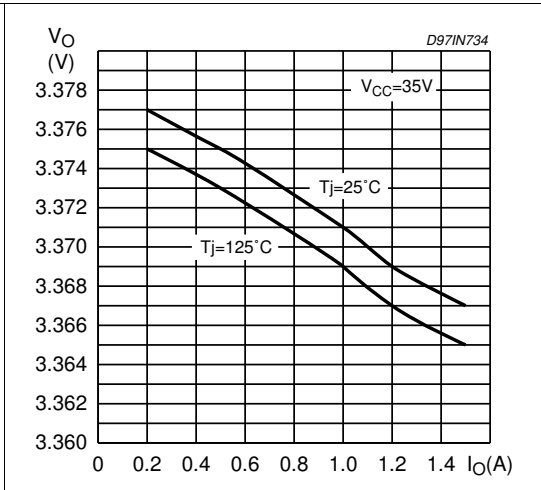

Figure 6. Quiescent current vs. junction temperature

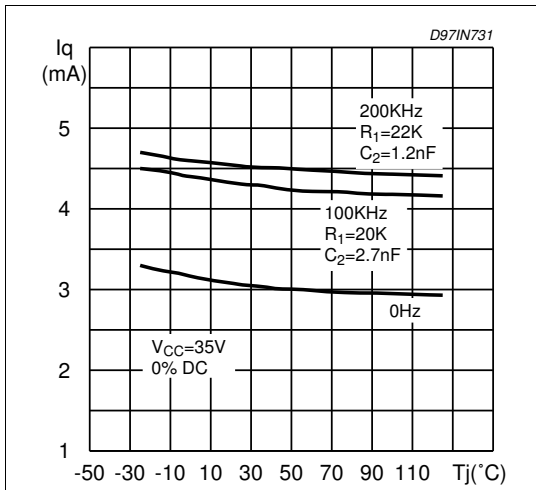

Figure 7. Switching frequency vs. R1 and C2

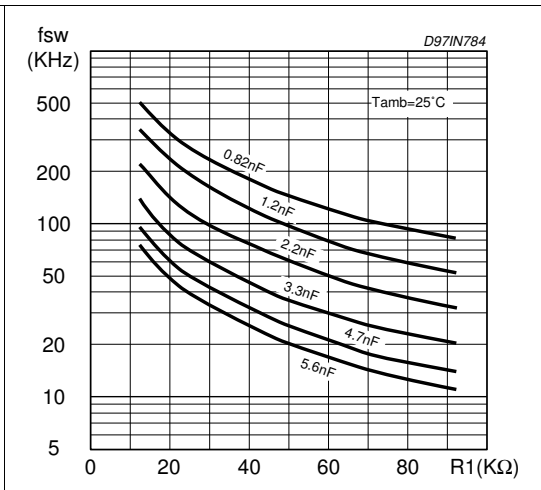

Figure 8. Load regulation

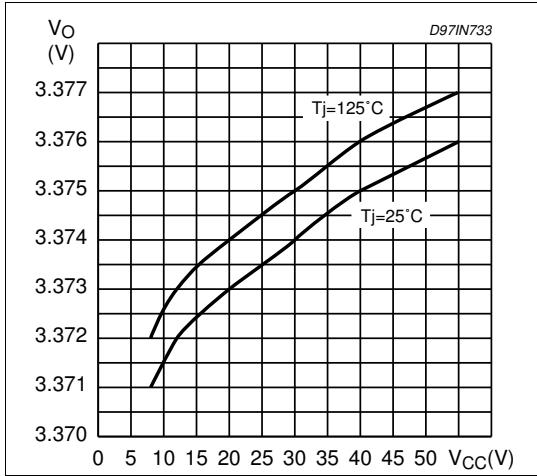

Figure 9. Switching frequency vs. input voltage

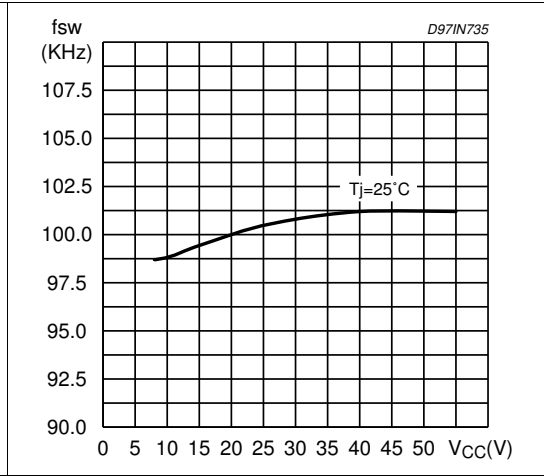

Figure 10. Switching frequency vs. junction temperature

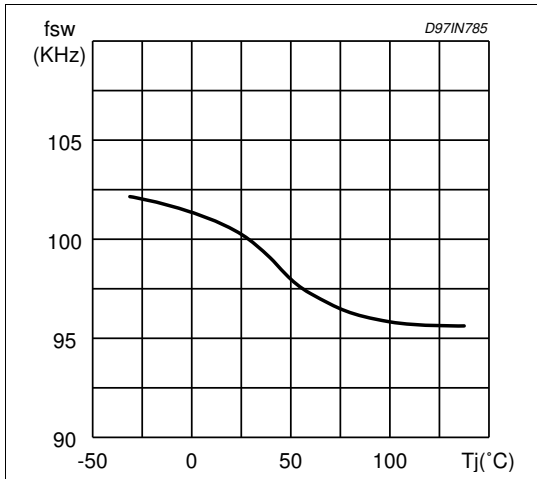

Figure 11. Efficiency vs. output current

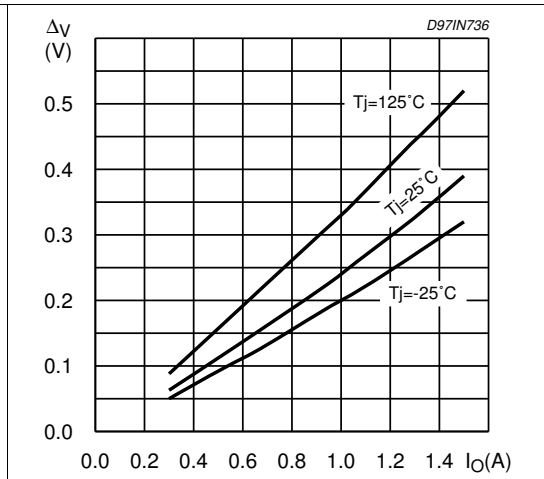

Figure 12. Dropout voltage between pin 5 and 4

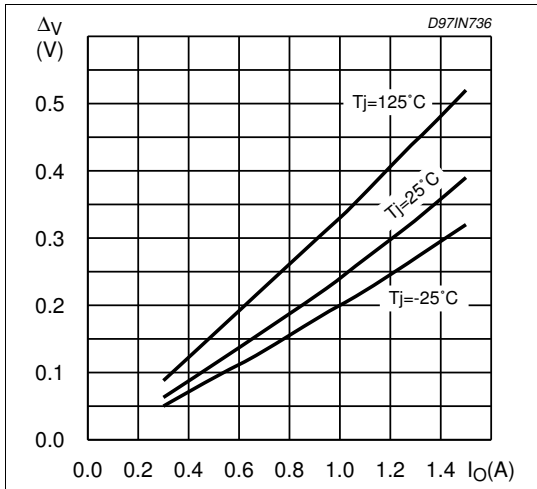

Figure 13. Efficiency vs. output current

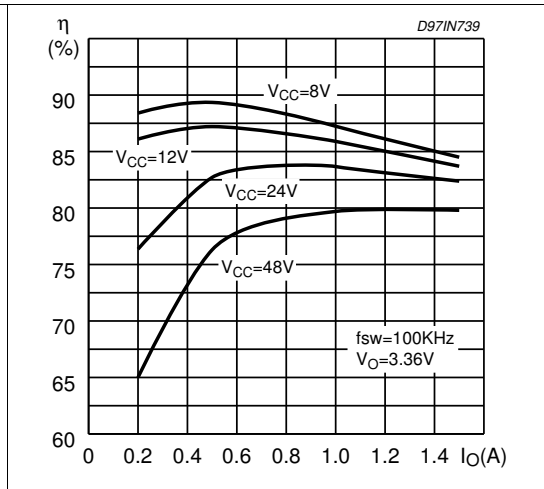

Figure 14. Efficiency vs output voltage

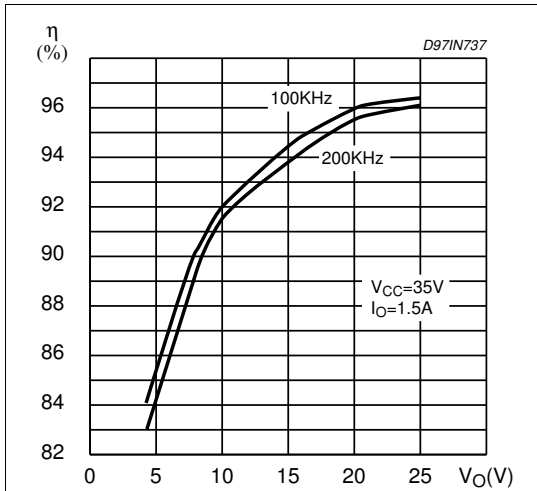

Figure 15. Efficiency vs. output current

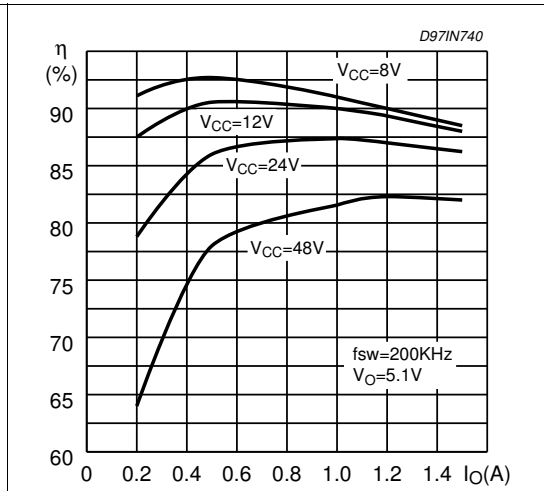

Figure 16. Efficiency vs. output current

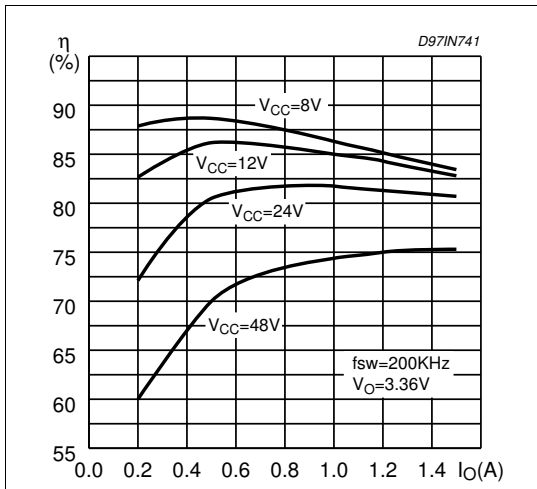

Figure 17. Efficiency vs. V_O

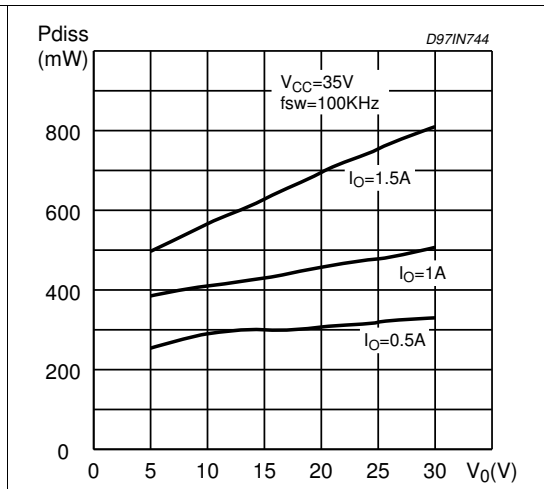

Figure 18. Efficiency vs. V_{CC}

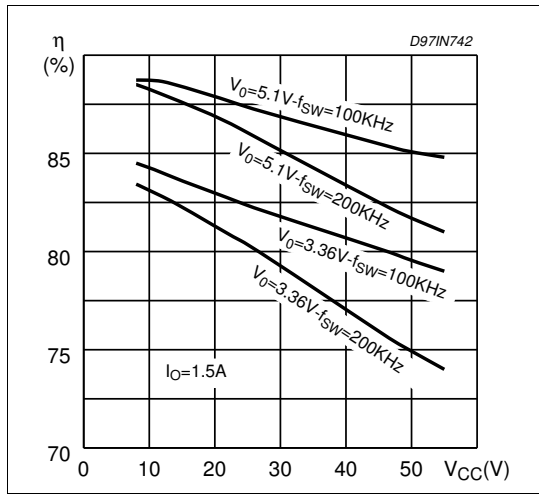

Figure 19. Pulse by pulse limiting current vs. junction temperature.

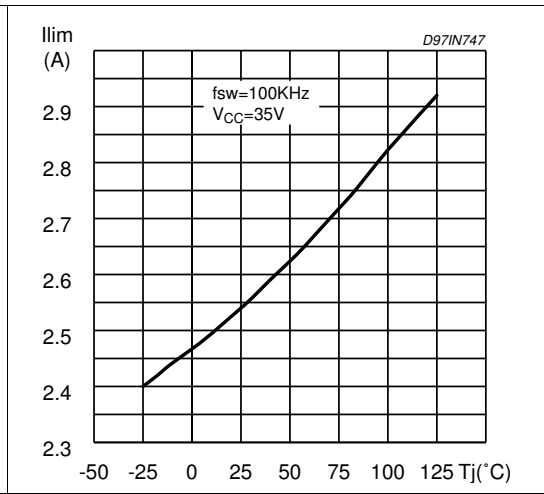

Figure 20. Power dissipation vs. V_{CC}

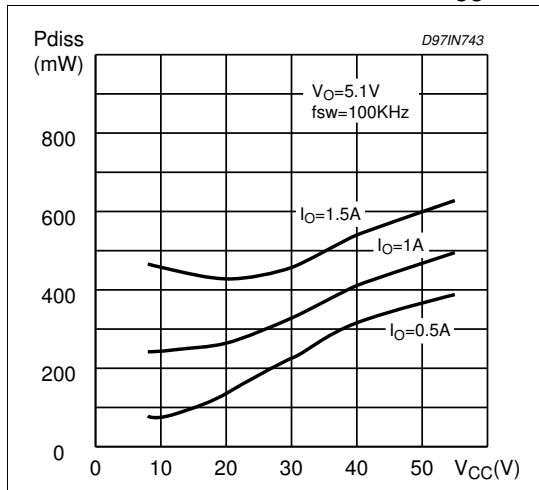

Figure 21. Load transient

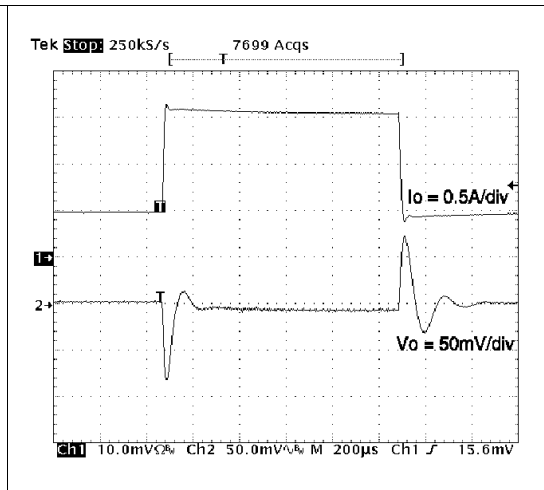

Figure 22. Line transient

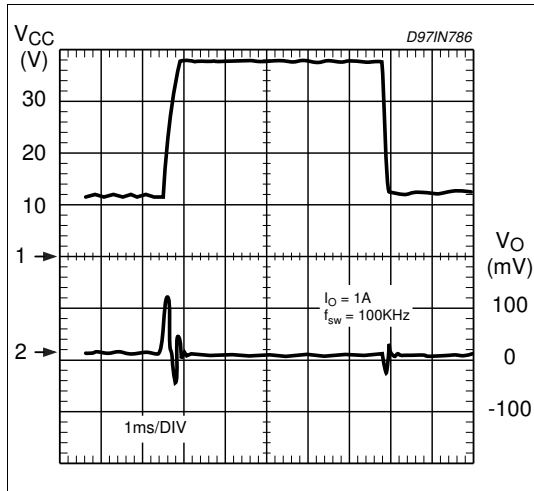
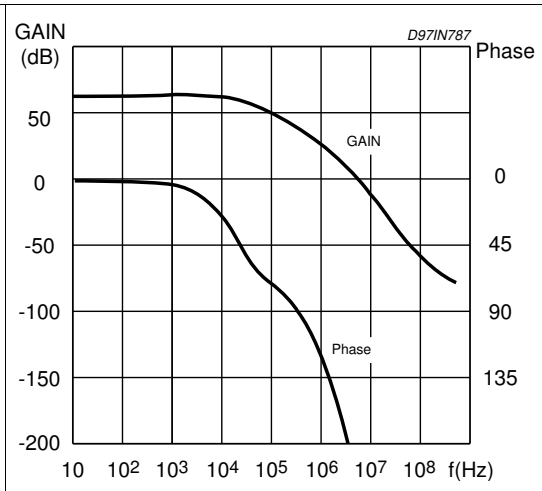

Figure 23. Open loop frequency and phase of error amplifier



6 Package mechanical data

In order to meet environmental requirements, ST offers these devices in different grades of ECOPACK packages, depending on their level of environmental compliance. ECOPACK specifications, grade definitions and product status are available at: www.st.com. ECOPACK is an ST trademark.

Figure 24. SO16Wide mechanical data & package dimensions

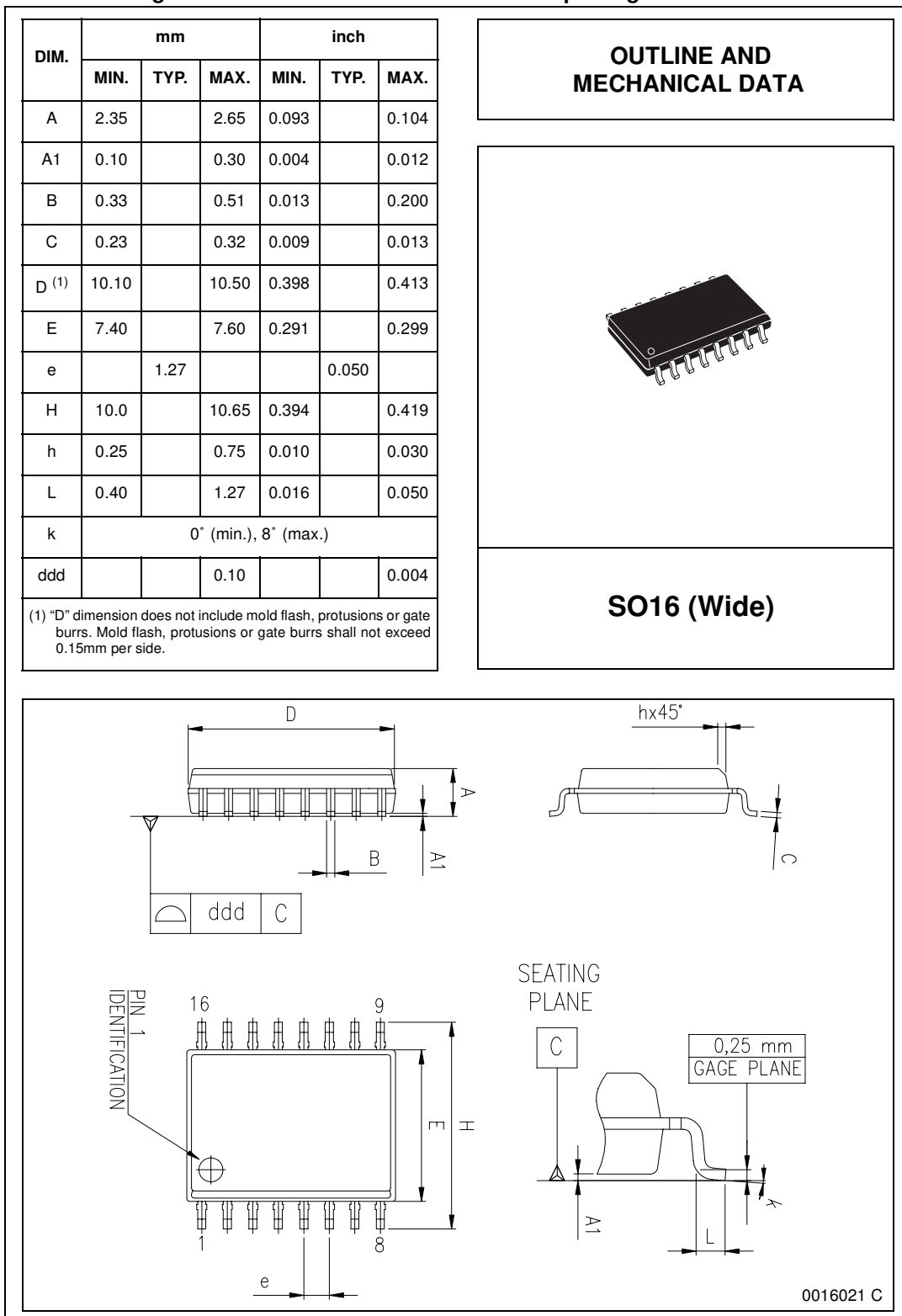

7 Order code

Table 6. Order code

Part number	Package	Packaging
L4976D013TR	SO16W	Tape and reel

8 Revision history

Table 7. Revision history

Date	Revision	Changes
5-Aug-2001	6	First Issue
3-Apr-2007	7	Document reformatted, updated dropout voltage values in Table 5 on page 6
14-May-2024	8	Updated Table 6

IMPORTANT NOTICE – PLEASE READ CAREFULLY

STMicroelectronics NV and its subsidiaries (“ST”) reserve the right to make changes, corrections, enhancements, modifications, and improvements to ST products and/or to this document at any time without notice. Purchasers should obtain the latest relevant information on ST products before placing orders. ST products are sold pursuant to ST’s terms and conditions of sale in place at the time of order acknowledgement.

Purchasers are solely responsible for the choice, selection, and use of ST products and ST assumes no liability for application assistance or the design of Purchasers’ products.

No license, express or implied, to any intellectual property right is granted by ST herein.

Resale of ST products with provisions different from the information set forth herein shall void any warranty granted by ST for such product.

ST and the ST logo are trademarks of ST. For additional information about ST trademarks, please refer to www.st.com/trademarks. All other product or service names are the property of their respective owners.

Information in this document supersedes and replaces information previously supplied in any prior versions of this document.

© 2024 STMicroelectronics – All rights reserved